



Eyal Gal 21.2-23.6GHz Transceiver by Roger Ray G8CUB

These units with the part number 6058-00 will work un-modified at 24.048GHz, with high side LO. They consist of a combined transmit and receive system. Just needing an LO at half frequency, Tx output filter, and a couple of relays to make a 24GHz transverter.

Measured performance on receive with a 432MHz IF, is as follows:

Conversion gain +26dB

System noise figure **TBD dB**

Image rejection (12.24GHz LO) -17dB

Performance on transmit:

+30.5dBm output - 1dB compression

+53dB gain

Saturated power output on transmit is >1.25W.

Supply requirements:

	Receive (Tx Inhibited)	Full Output
+8.0V	1.05A	1.05A
+12V	780mA	1.15A
-12V	80mA	80mA

The IF response is flat **TBD - TBD** MHz. With the high transmit gain, it is necessary to either use an input attenuator, or use the AGC control to turn the gain down.

My existing 24GHz system is an Alcatel unit using the Alcatel synthesiser, already with high side injection, and 10MHz reference. So I was ready to try the Eyal Gal block. The block dissipates a fair amount of heat when in transmit mode, so additional heat-sinking may be required for FM use.

A specification sheet was available on the web <http://www.eyal-emi.com/siteFiles/1/32/1081.asp> This suggested that operation on 24GHz might be possible. The original IF was 2.8 – 4.1GHz, so would they work with a 432MHz IF? The real novelty is that the data included both pin-out, and voltages! The modules are designed for linear operation, so it was hoped to get around +27dBm out. In fact the first unit that I tried gave +31dBm, a very useful power level at 24GHz. Performance on receive is good with +26dB conversion gain, with the image -17dB. On transmit it is necessary to use a filter on the output to reduce the LO and image to acceptable levels.

Pin-out on the two connectors as pictured above, left to right, is as follows.

Connector 1 (6 way)

6	5	4	3	2	1
n/c	+8V	-12V	0V	n/c	+12V

Connector 2 (7 way)

7	6	5	4	3	2	1
Rx	Tx Det	AGC	0V	n/c	n/c	Tx Mute

Agc

Connections to the unit are by two, 0.1” pitch single in line connectors..

Tx Mute – 0V to inhibit

Tx Det – DC proportional to dB output power (log detector) Max ~ TBD V

AGC – 0- 5V Control - from the data sheet turning the power down more than 10dB will limit the output power (I have not tried this, just left the pin o/c)

Local oscillator power required is +10dBm (12.24GHz). Around -22dBm Tx drive will give you full output (at max gain). Both receive and transmit RF is WR-42 (wg20) waveguide.

Block diagram

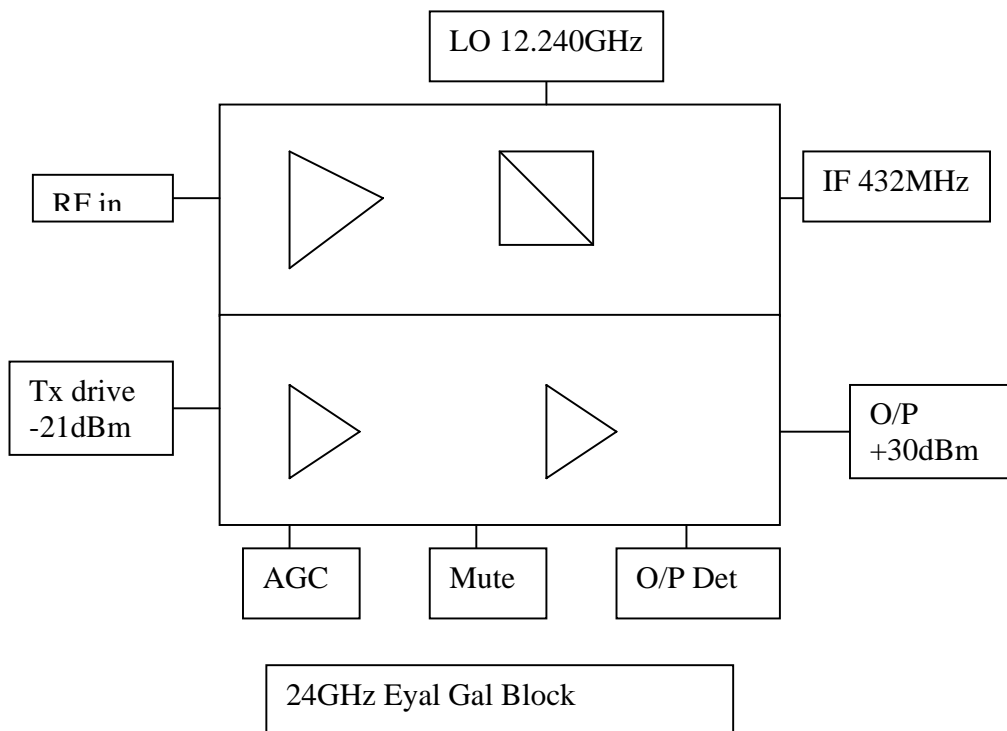

24GHz unit with filter and PIN waveguide switch



Availability

Modules are appearing on ebay, again mainly from dealers in Israel. I have a couple of modules, which I will make available to members on a first come first served basis. £75 each Plus postage of £3.50 UK, £6.50 Europe. Contact Roger on 07900 261121 email: littlemallards@hotmail.com